



MODERN OFFICE SYSTEM

6901.001



Gas spring structure offers perfect counterbalance presentation in all directions
Built-in spring tension gauge can be easily adjusted to fit varied weights the arm holds.
360° rotate and -90°~+90° tilt VESA plate design
Available for freely adjusting height without tools
Cable management feature routes cables under the arm, out of sight
Both grommet and desk clamp mounting available

M	Aluminum and Steel
Suggested Screen Size:	13"-27"
Rated Load:	9KG / 19.8lbs
VESA:	100x100; 75x75
Tilt:	+90°~-90°
Swivel:	+90°~-90°
Rotate:	360°
Clamp Range:	10 mm- 88mm

6901.002



Built-in spring tension gauge can be easily adjusted to fit varied weights the arm holds.
Both grommet and desk clamp mounting available
Gas spring assisted arm helps easy adjustment for viewing
Fully adjustable: 360°rotate , 180°tilt and 180°swivel
Integrated cable management to keep desk uncluttered

M	Aluminum and Steel
Suggested Screen Size:	13"-24"
Rated Load:	5.5KG / 12.1lbs
VESA:	100x100; 75x75
Tilt:	+90°~-90°
Swivel:	+90°~-90°
Rotate:	360°
Clamp Range:	10mm- 88mm

6902.001 Single Motor Two Sections

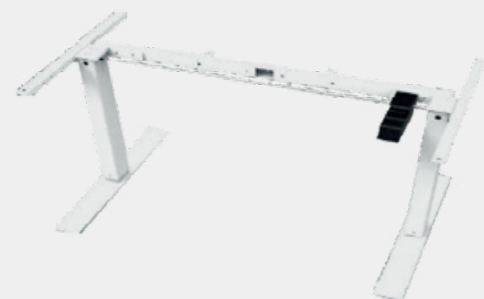

Lifting Range:	620 – 1270mm
Frame Adjust:	1100 – 1600mm
Load Capacity:	80kg / 180lbs
Full Load Speed:	26mm / second
Input Voltage:	AC 90V – 230V
Output Voltage:	DC 24V
Noise:	below 35db
Adaptive Memory Function Handset	



6902.004 Single Motor Three Sections



Lifting Range:	610-1260mm
Frame Adjust:	1100-11500mm
Load Capacity:	80kg/180lbs
Full Load Speed:	28mm/second
Input Voltage:	AC 110-230VAC
Output Voltage:	DC 24V
Noise:	below 35dB
Adaptive Memory Function Handset	

6902.002 Double Motor Three Sections



Lifting Range:	620 – 1270mm
Frame Adjust:	1100 – 1600mm 1400 – 2200mm
Load Capacity:	120kg / 265lbs
Full Load Speed:	30mm / second
Input Voltage:	AC 90V – 230V
Output Voltage:	DC 24V
Noise:	below 35db
Touch Screen Memory Function Handset	

6902.003 Three Motor Three Sections



Lifting Range:	620 – 1270
Frame Adjust:	1100 – 1600
Angle adjust range:	90° – 220°
Load Capacity:	150kg / 330lbs
Full Load Speed:	30mm / second AC
Input Voltage:	90V – 230V
Output Voltage:	DC 24V
Noise:	below 35db
Touch Screen Memory Function Handset	



No.	Ø * H	M
6601.001	35*16	ABS
6601.002	38*16	ABS
6601.003	45*16	ABS



No.	Ø * H	M
6603.001	60*20	ABS
6603.002	80*20	ABS



No.	Ø * H	M
6604.001	50*20	ABS
6604.002	60*22	ABS
6604.003	63*22	ABS
6604.004	66*15	ABS
6604.005	66*20	ABS
6604.006	80*22	ABS



No.	Ø * H	M
6605.001	66*20	ABS
6605.002	66*25	ABS



No.	Ø * H	M
6606.001	60*22	ABS
6606.002	80*22	ABS



No.	Ø * H	M
6607.001	50*20	ABS
6607.002	60*22	ABS



No.	Ø * H	M
6651.001	60*19	ABS



No.	Ø	H	M
6652.001	60	15-22	POM

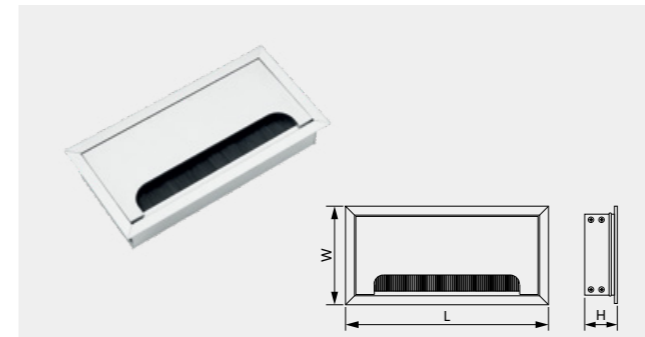

No.	L * W * H	M
6650.001	160 * 80 * 25	Aluminum
6650.002	280 * 80 * 25	Aluminum

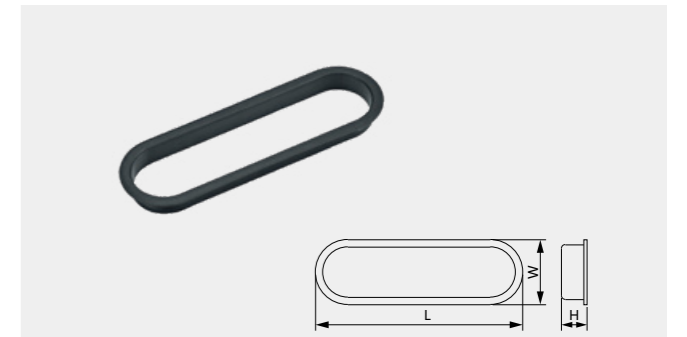

No.	L * W * H	M
6609.001	190 * 59 * 16.6	PP



No.	L * W * H	M
6612.001	550 * 270 * 35	PP/ABS



No.	L * W * H	M
6613.001	550 * 270 * 35	PP



No.	H	M
6611.001	800	PP

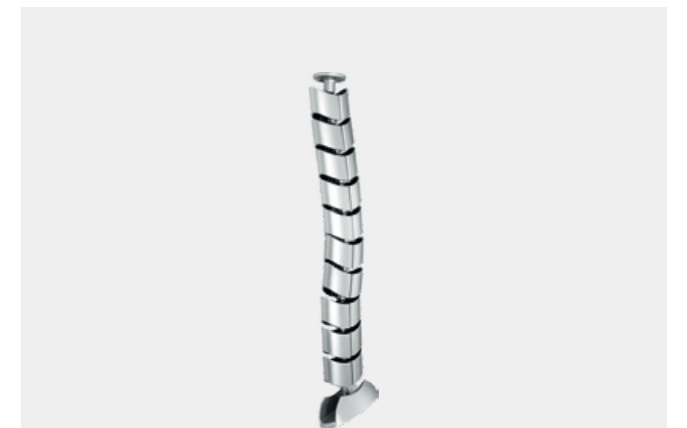

No.	H	M
6611.002	800	PP